



SSB Aboard – SSS Seminar 2010

Brian Boschma

Agenda

- Antenna Choices
- Electrical Connections
 - Ground connection versus RF ground connection
 - Forcing RF to stay along desired paths
 - Using Ferrites
 - Making a connection to the sea – RF ground
 - 12 volt – Radio – Tuner
- Radio Selection
- Testing your install as you go
 - Suppression of noise and instrument interference.
 - Ferrites / Capacitors/Filters – Jesus Beads
 - Using radio features
 - Power output
- Nav instrument/autopilot interference
- Propagation Theory
 - Time vs Frequency (single slide)

Antennas

Split backstay

GAM – backstay

Whip



- Backstay options
- Rail mount options
- Other configurations – several will work

Antenna Installations That Work

- Backstay:
 - Stainless wire: need two insulators to isolate
 - Many installations successful
 - Costly insulators required.
 - High Tech Fiber backstay: Run insulated #16 under cover
 - Summer Moon 2008, Solid check ins
 - Parallel wire in sleeve, slides over existing backstay.
 - Elise Express 27 2008, Solid check ins, one of best signals
 - <http://gameelectronicsinc.com/ssb.htm>
- Whip antenna to stern pulpit:
 - Shakespere 21' whip – recommended length for tuners:
 - Redsky 1998, 2000 - Comm boat, great signal
 - Eyrie 2004 , 2006 - Solid reports

Antenna's with questionable results

- Loaded whips (Outbacker) – high loss at 4 MHz.
- Short whips (< 17' ?) – high loss at 4 Mhz
- Connection to Un-insulated backstays
 - Redsky 2009 Long Pac, solid signal
 - May work, may cause other interference and noise in receiver.
 - Tuner results not assured, tune solution could change with motion and water contact to rigging in wave action. Would seem like broken signal.

Emergency Antenna and Ground Backup

- Carry 20' of #14 insulated stranded wire..
- **Toss the wire** over highest point on boat and tie to tuner, or wire that was tied to tuner.
- Ground Backup: If you suspect your ground connection has failed toss wire into water and connect to tuner ground point – in this application strip back 24" of insulation on end going into water.

Why a Connection to the Sea ?

Ground Plane

- $\frac{1}{4}$ wave or shorter Vertical over infinite ground plane couples energy into the ether
 - Simplest solution on a small vessel.
 - Challenge is coupling to the infinite ground plane (the ocean)
- $\frac{1}{2}$ wave Dipole – two resonant wires energized in opposition (+/-) couples energy into the ether.
 - Too long at 4 Mhz for small vessels.

Ground Plane – Key to Success

- Sea water is a conductor and a great contributor to the radios performance. Creates infinite ground plane
- A RF connection to the sea is as important as the antenna as it completes the propagation circuit.
 - What boats have outstanding signals ?
- RF coupling to ocean – surface area (capacitive) or direct connection to water is key:
 - Keel connection (I have used this on 6 vessels, no checkins missed)
 - Foil liner in hull against inner hull surface – need a lot of area.
 - Conductive plates on hull – direct connection.
 - Propeller shaft – carbon brushes for a direct connection
 - Engine block connection –adds area
 - Tie to metal thru hulls.
 - A copper braid/plate over the side at checkin – backup ?
 - Resonant ground plane – a bit esoteric – 39' in length

RF Currents Flow on Surface of Wire

DC Currents flow throughout volume

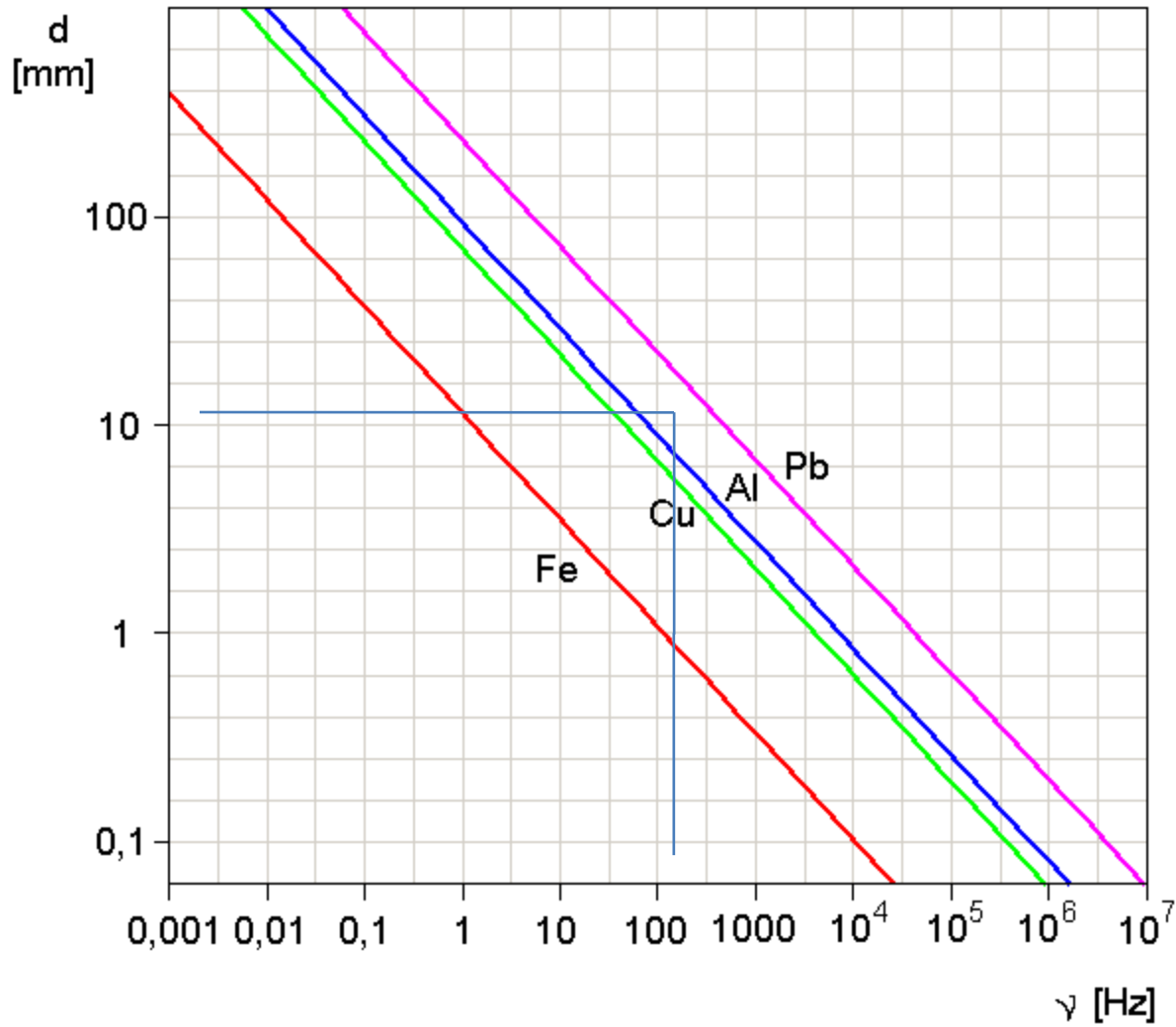

4MHz depth of Conduction \sim .05mm

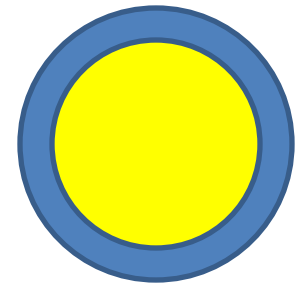



Grounding At Commercial Radio Station KESE Monterey – 1.2 MHz (1240)



Commercial Radio Station in Monterey making GROUND Connection with copper strap to copper pipe. Point: Surface area is what matters not large copper crosssection.

Commercial SSB – FCC Type Approved – Channelized – One button to Guard Frequency



- Water tight mics
- High quality connectors, O ring seals, etc.
- Frequency control more accurate
- Channelized to Marine Band



Amateur Radio SSB – not Type Approved – Smaller, Cheaper, Need - modification to operate on commercial SSB frequencies.

- More susceptible to moisture, especially at Mic connections
Mic not sealed.
- No push button access to emergency frequencies
- You can set radio up for channelized operation.
- General use by crew may require some training.
- EMAIL use may cause overheating – lower power as precaution.



Connections for RF

RF will take any path to return to the xcvr

Chokes(Ferrite) channel the RF along the desired path

RF along other paths result in interference in radio and instruments

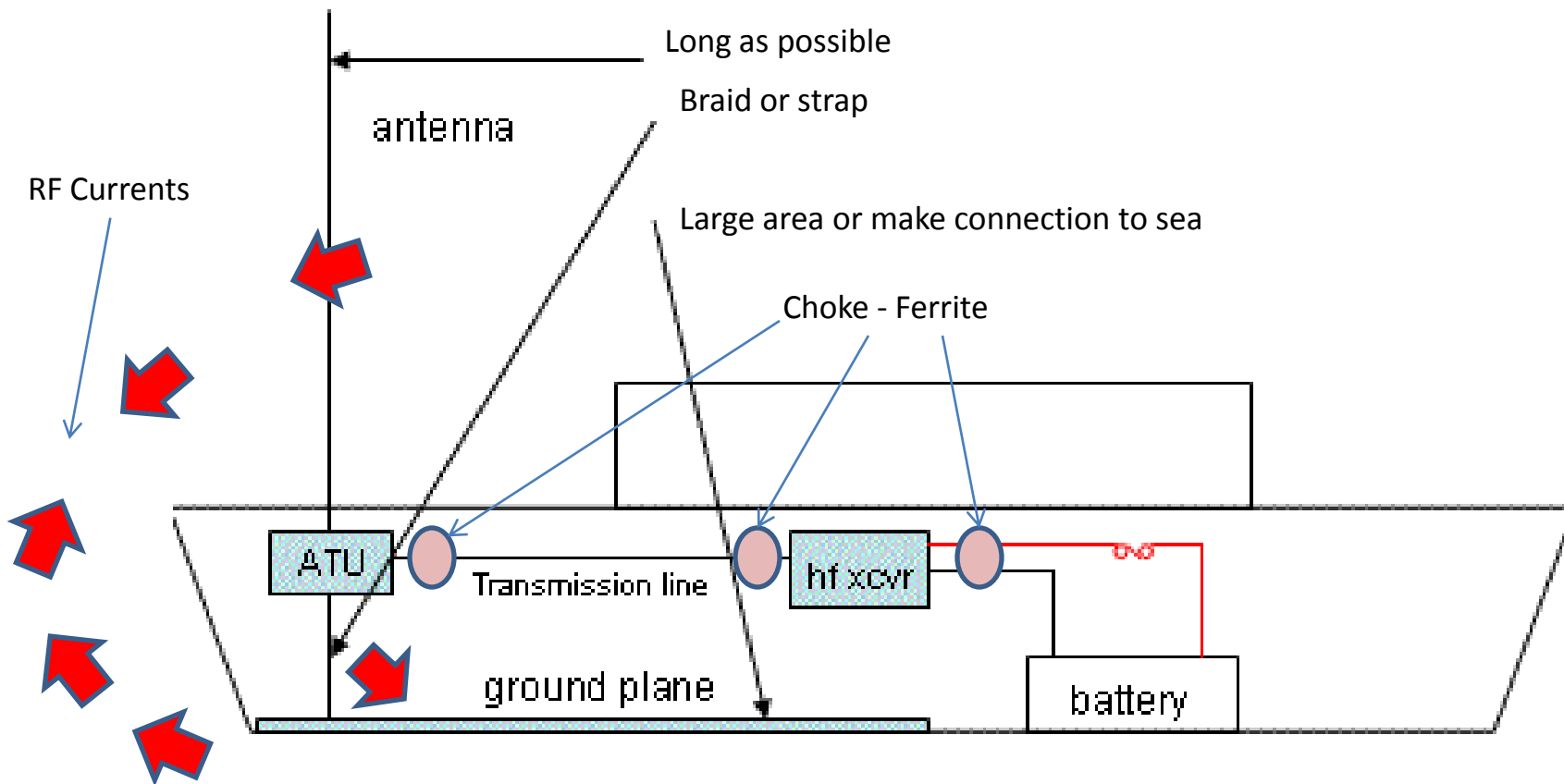

Battery Connections to Eliminate Noise

– Improper Routing

SSB receives signals that are a million times smaller than the signaling levels used by instruments. Shared electrical paths can induce noise into the radio larger than what is being received.

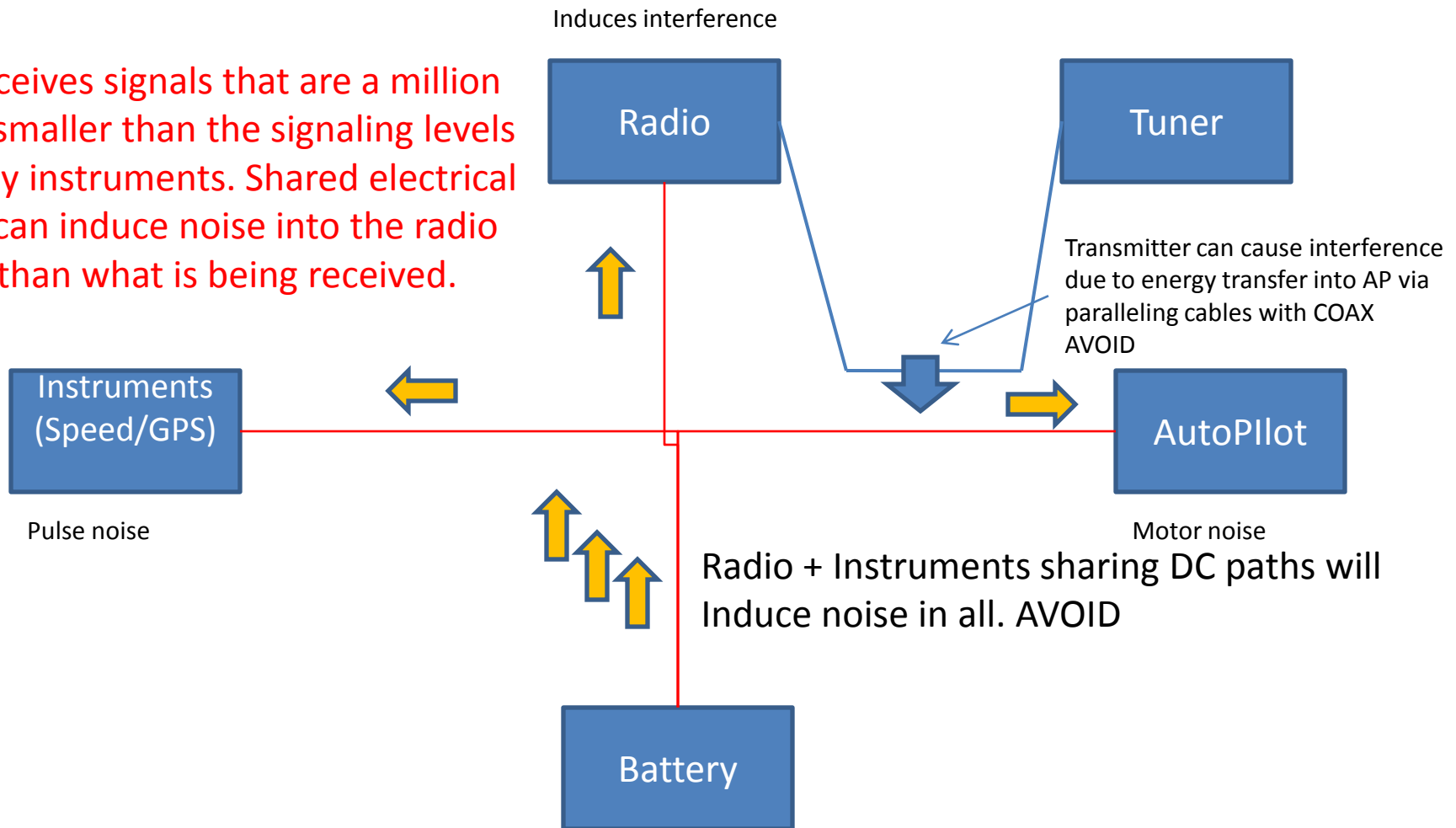

Battery Connections to Eliminate Noise

– Best Routing

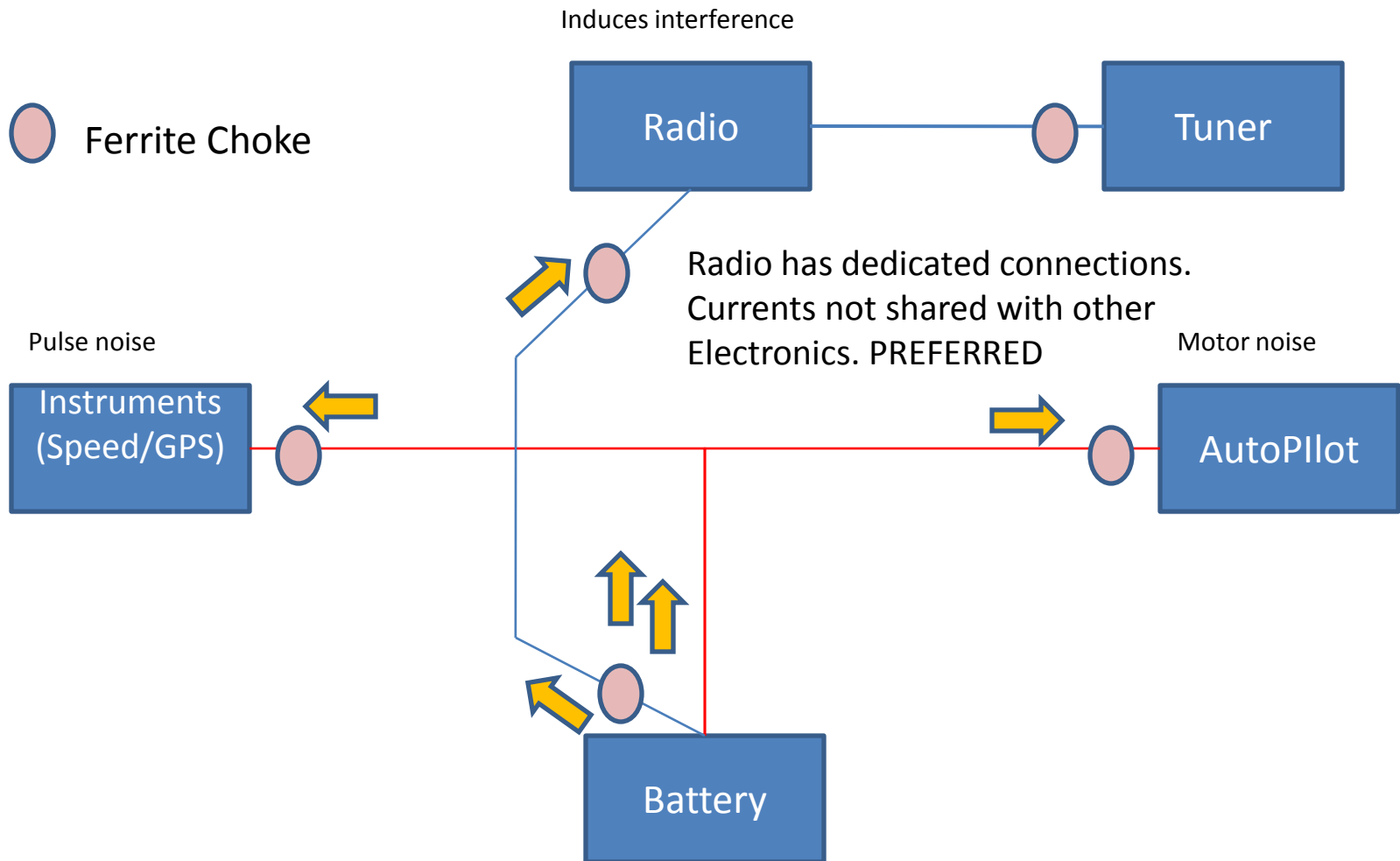

Enhanced Noise Filter – good for AP motor noise or GPS pulse noise

Choke(Ferrite) – a few turns of wire through ferrite core

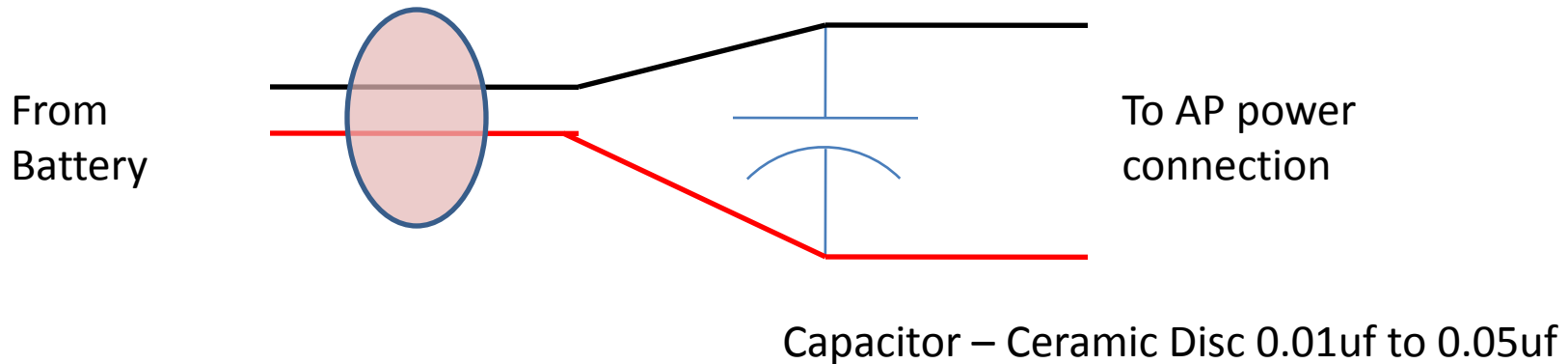

Tuners



Tuner installation Problems

- Can't get full power at some frequencies
 - Small wire coil in series can solve this, test all important frequencies.
- Intermittent receive/transmit –
 - Coax connections.
 - Power connections
 - Antenna connection – salt corrosion
- Ground Plane connection is key, don't skimp here, use high surface area ground braid to connect to boat RF ground.

Tuner – Caution

Length Matters, Damage Can Occur as Ant.
Approaches a $\frac{1}{2}$ Wavelength

Frequency	Half Wave Length in ft. - Avoid
4146	118.4
6224	78.9
8297	59.2
12353	39.8
16200	30.3
22160	22.2
25160	19.5

When tuner is looking into a $\frac{1}{2}$ wave antenna voltages become very high and can break down tuner components.

Are You Getting Power to and Out of the Tuner ? - debug

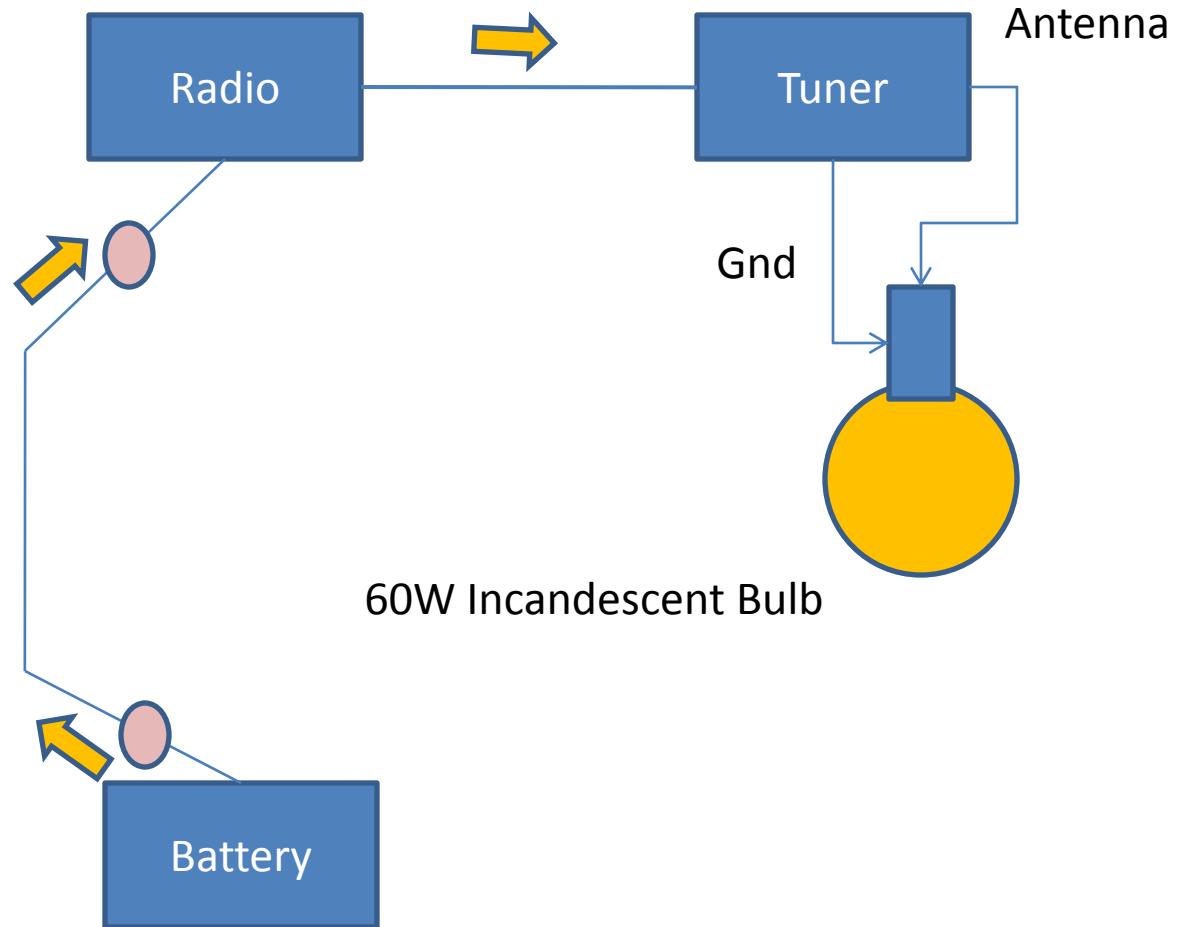

Are You Radiating Energy from the Antenna and Ground ?



Multimeter, 15 turns of wire, and a diode make it possible to do a crude measurement of Antenna/ground operation.

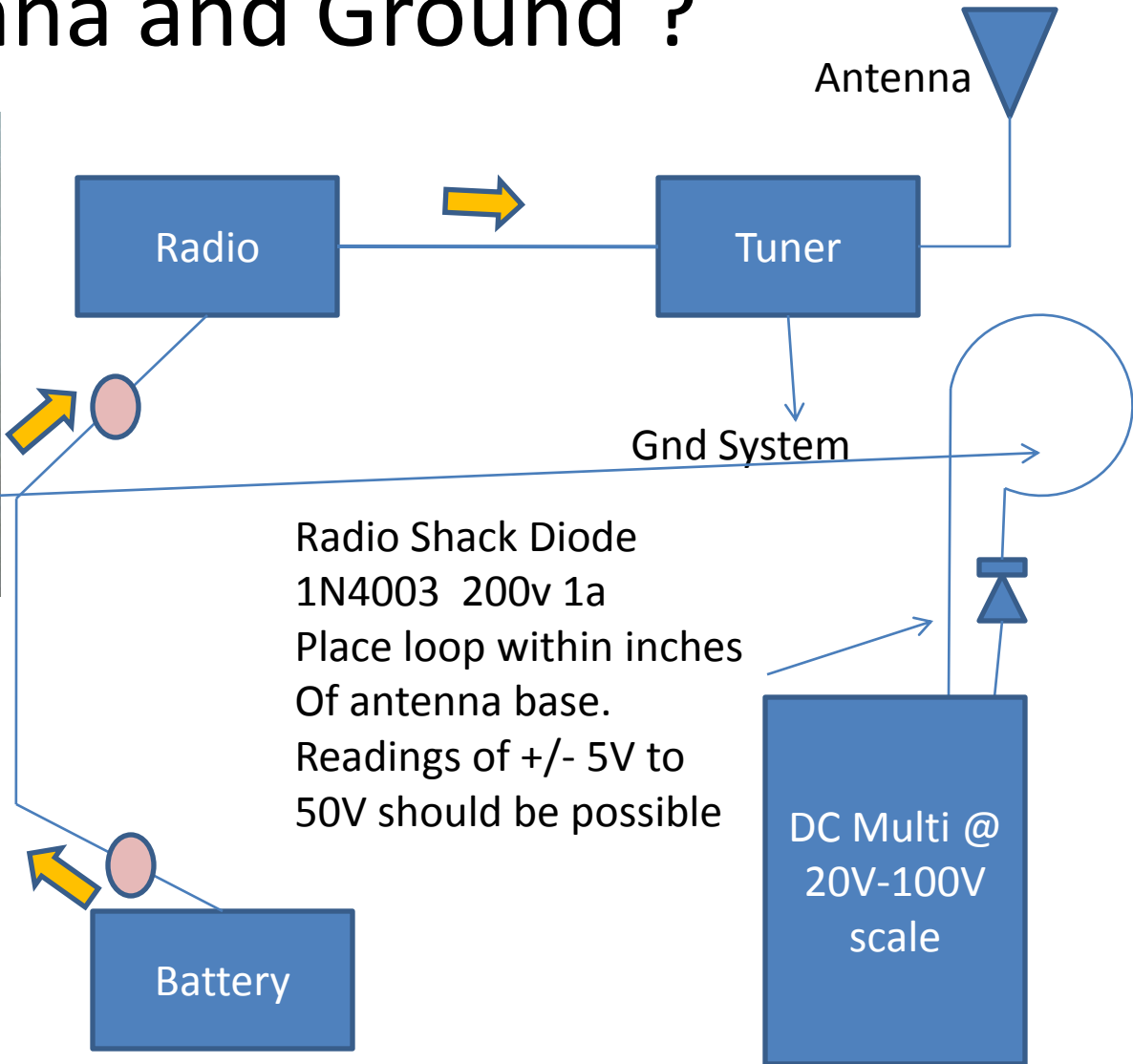

Short Range SSB Propagation (Fleet Check ins)

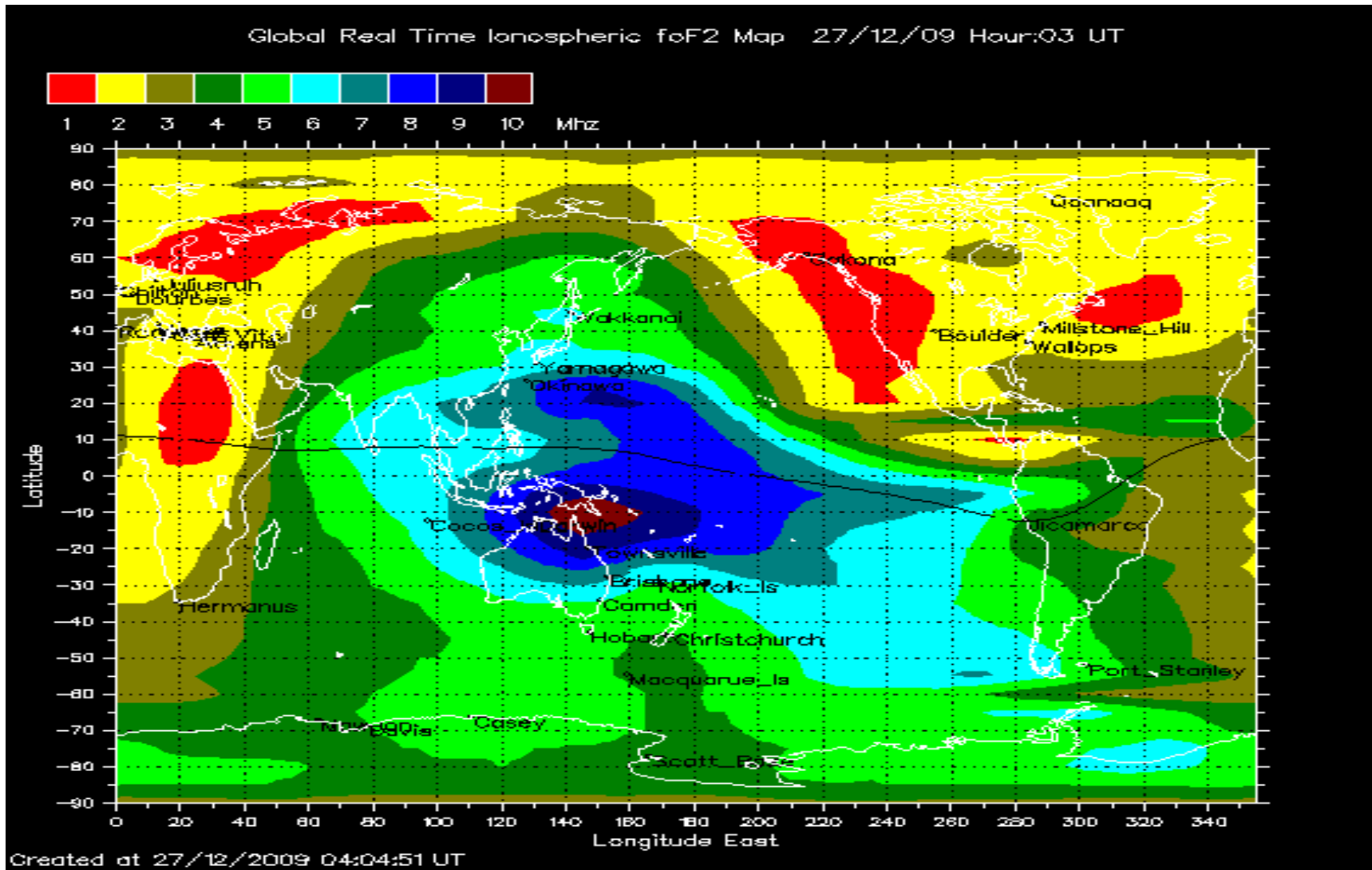

Sunlight Map at Time of Propagation Map

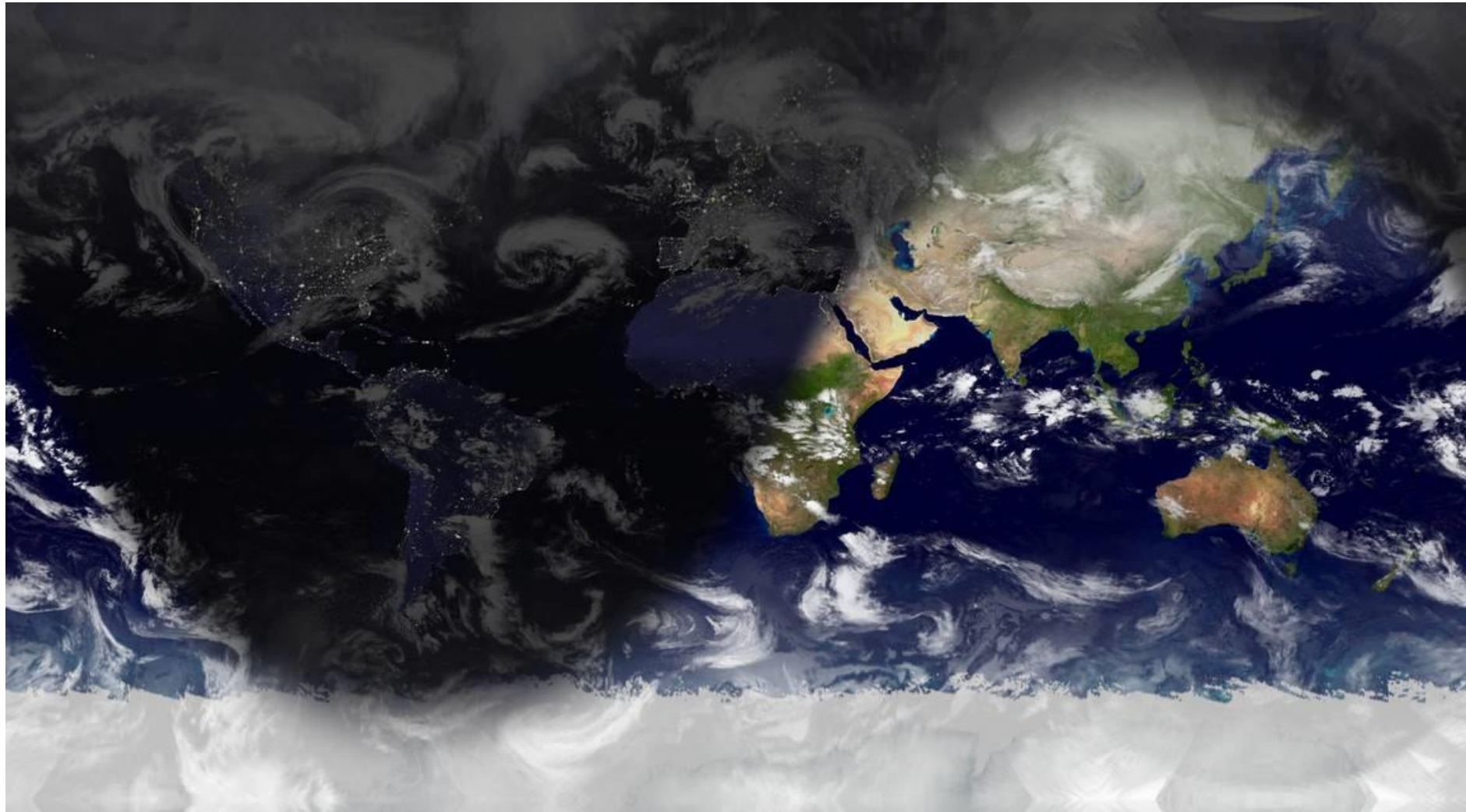

Useful Coax Connectors (SO239)



Insert to fit RG58 or RG8X

Join two cables

Quality: Avoid crimp connectors.
Solder all connections if possible.

Where possible use silver plated with Teflon insulator (avoid radio shack connectors especially if soldering)

Suppliers:

Ham Radio Outlet – Oakland, Next to West Marine, you were going there anyway

Ham Radio On Board – Alameda

RF Parts Inc – mail order, usually good prices, cable/connectors/strap

Coax Cable – RG8X or RG58 Are Your Choices

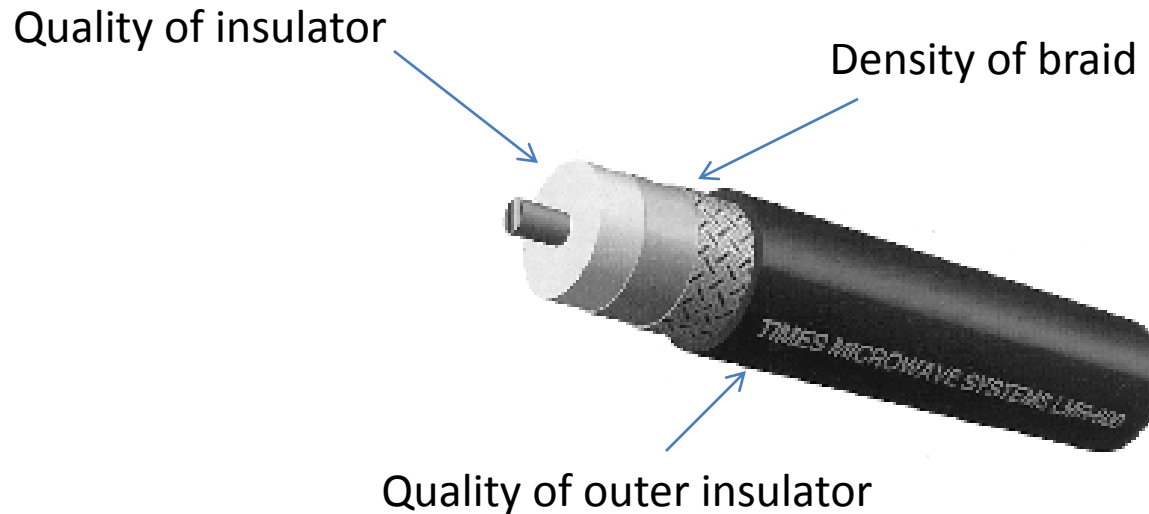

Wrong coax – could result in ~30% signal loss.

Low quality coax – could result in ~ 5% loss, but long term corrosion an issue.

Ancor, Belden are great. Radio Shack less. All work initially. Quality concerns are absorption of moisture, corrosion rate, RF loss over distance. first two are of most concern to small boats.

RF Connectors/Coax/Braid/Copper Strap



Surplus Sales
of Nebraska

*Made like they used to be.
Vintage parts with Superior Quality!!!*

402-346-4750

The Original
WIREFORMAN

Ham Radio On Board (Alameda)
Ham Radio Outlet (Alameda
Sunnyvale)
Haltek Surplus Sunnyvale
West Marine (some gear)

What Can Go Wrong

- Low battery voltage
 - When radio voltage drops below ~11.7 volts a distorted signal can occur (nature of the radio design)
 - Quick cure – lower power level to minimum and relay to near by boats. Rarely do you need 100 watts.
 - Assure batteries are charged well (~12.5 or more)
 - Make certain you have solid connections to the radio without corrosion.
- Microphone is single point of failure.
 - Make sure connections are not subject to water exposure.
 - Make sure microphone is not subject to exposure to wet hands/gloves (cover with plastic bag ?).

What Can Go Wrong

- Antenna wire connection corrodes at backstay termination (hidden under tape).
 - Use conductive grease when installing.
- Ground straps/antenna connections corrode or loosen.
 - Assure tuner connections are solid. Use thread locker on screw terminals or lock washers.
- Coax connectors short / open / corrode
 - Solder coax connectors.
 - Check for shorts after each is installed.
 - Avoid crimp on coax connectors, carry for back up only.
 - Avoid coax in bilge water (long term).
 - Avoid exposed braid where moisture could be wicked in.

Radio Tower Base



$\frac{3}{4}$ " Copper pipe carries transmitter signal into sand for a ground to salt water.

Surface area is key for RF conduction, RF energy flows on surface of wire.

Copper strap is good against hull as it maximizes surface area to water.

Keel: large area to take advantage of